

CONTENTS

- 1) GENERAL INSTRUCTIONS
- 2) SAFETY STANDARDS
- 3) INSTRUCTIONS FOR USE
- 4) IDENTIFICATION OF MACHINE PARTS
- 5) REPLACING THE MEMBRANE
- 6) SPARE PARTS
- 7) GENERAL CONDITIONS OF SALE

1) GENERAL INSTRUCTIONS

Firstly, we wish to thank you for having purchased our product.

For many years our firm has been manufacturing oenological equipment for small and medium-size wine makers.

When producing our articles, we always endeavour to make them practical to use, safe, high quality and long lasting; to ensure that they are, please read the booklet carefully.

The water press is a press suitable for pressing chopped apples, destemmed grapes and other product types, providing they have no stones or other hard or sharp parts which could damage the membrane.

Pressing with the water press is a recent and extremely efficient system which makes use of the existing pressure in the domestic water mains and which, when connected to the press by means of a pipe, delivers water through the central shaft (perforated inside) to the membrane, dilating it evenly towards the outside and consequently compressing the product to be pressed against the perforated stainless steel cage.

The lid, collection base, perforated cage, central shaft and outer flange are all made of AISI 304 stainless steel, the membrane is made of non-toxic rubber.

IMPORTANT:

THE MACHINE MUST ONLY BE USED WITH WATER, AND NEVER WITH AIR OR OTHER GASES. In the event of the membrane or cage exploding with the use of air or other products differing from water, besides declining all responsibility, our Company will also demand moral damages and damage to corporate image.

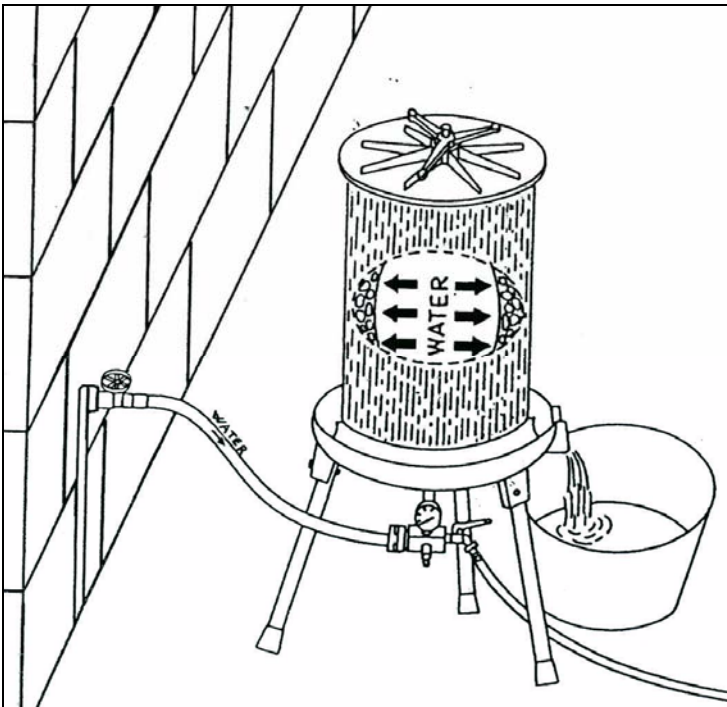

2) SAFETY STANDARDS

Improper use and incorrect maintenance can cause damage to persons or property. To prevent possible accidents, comply strictly with these safety standards.

- 1) INSTRUCTIONS Only use the water press after reading this booklet which, in the event of loss, can be requested from: Zambelli Enotech srl Via dell' Artigianato Z.A. –36043 Camisano Vicentino Italy
- 2) POSITIONING Make sure that the machine is positioned in a safe place, on a flat surface, to guarantee the stability of the water press during operation
- 3) USE Do not allow children, unauthorized persons or those without sufficient knowledge of its use to utilise the water press.
- 4) PROHIBITION **The use of air or other gases to inflate the compression membrane is strictly prohibited.**
- 5) SAFETY VALVES Under no circumstances must the safety valves, set in the factory to 3 Atm, be tampered with or excluded. In the event of breakage or malfunction, they must be replaced before using the water press again, and can be requested from the manufacturer or authorized dealer.
- 6) WARNING Before inflating the membrane with water, make sure that the cage is in its seat, that the lid is inserted accurately on the cage and that the handle is screwed down tightly on the lid.

3) INSTRUCTIONS FOR USE

- CLEANING: Before starting to process it is advisable to thoroughly clean the perforated cage, the lid, the handle and the base.
- CONNECTION Connect the water pipe of the mains supply to the loading unit (N°4) using the connection 4a. Then connect another pipe to the discharge valve (N°5) of the water press.
- LOADING THE PRODUCT Unscrew the handle (N°1) and lift the lid (N°3) from its seat . Place the inner bag inside the drum, folding the upper edge evenly on the outside of the drum and start loading the product evenly.

OPERATION

After filling the drum, take the edges of the bag and fold them towards the inside of the drum, position the lid in its seat (over the drum), grasp the handle and screw it down.

Open the top vent (N°2) and fill the inner membrane with water through the loading unit (N°4); close the top vent when water spills from it; cover the entire water press with the outer bag, making sure that the lower edges are positioned inside the collection base, to prevent splashing. Pressing will now begin, and terminates when the pressure reaches 3 Atm.

At this point turn off the water supply with the valve 4B, wait until all the product has been delivered, remove the outer bag and open the discharge valve (N°5). Once all the water has been discharged from inside the membrane remove the lid, pull the catch (N°6), releasing it from the first seat and rotate the entire water press through about 90° until the catch engages in the second seat.

Once the water press is in the horizontal position, place a box for collection of the dry product (waste) under the mouth of the drum, take the inner nylon bag, shake it gently and remove it with all the product from inside the drum. After having removed the bag with most of the product, clean the inside of the water press thoroughly and then, pulling the catch again, return the water press to the vertical position. At this point it can be reloaded.

LOADING UNIT WITH SAFETY VALVES

The loading unit is provided of:

- 4d safety valve: ensures that a pressure of 3 Atm is not exceeded, by discharging excess pressure.
- 4a quick coupling,
- 4b ball valve 1/2" M/F,
- 4c block,
- 4e gauge,
- 5 discharge valve.

ORDINARY MAINTENANCE

The water press does not require special maintenance; thorough cleaning is recommended and it is advisable to cover the press when storing to protect it from dust.

4) IDENTIFICATION OF MACHINE PARTS

- 1) HANDLE
- 2) TOP VENT
- 3) LID
- 4) LOADING UNIT
- 5) DISCHARGE VALVE
- 6) CATCH

VIEW 'X'

- 4a) SWIFT QUICK COUPLING
- 4b) BALL VALVE 1/2 M/F
- 4c) BLOCK
- 4d) SAFETY VALVE
- 4e) GAUGE
- 5) DISCHARGE VALVE

5) REPLACING THE MEMBRANE

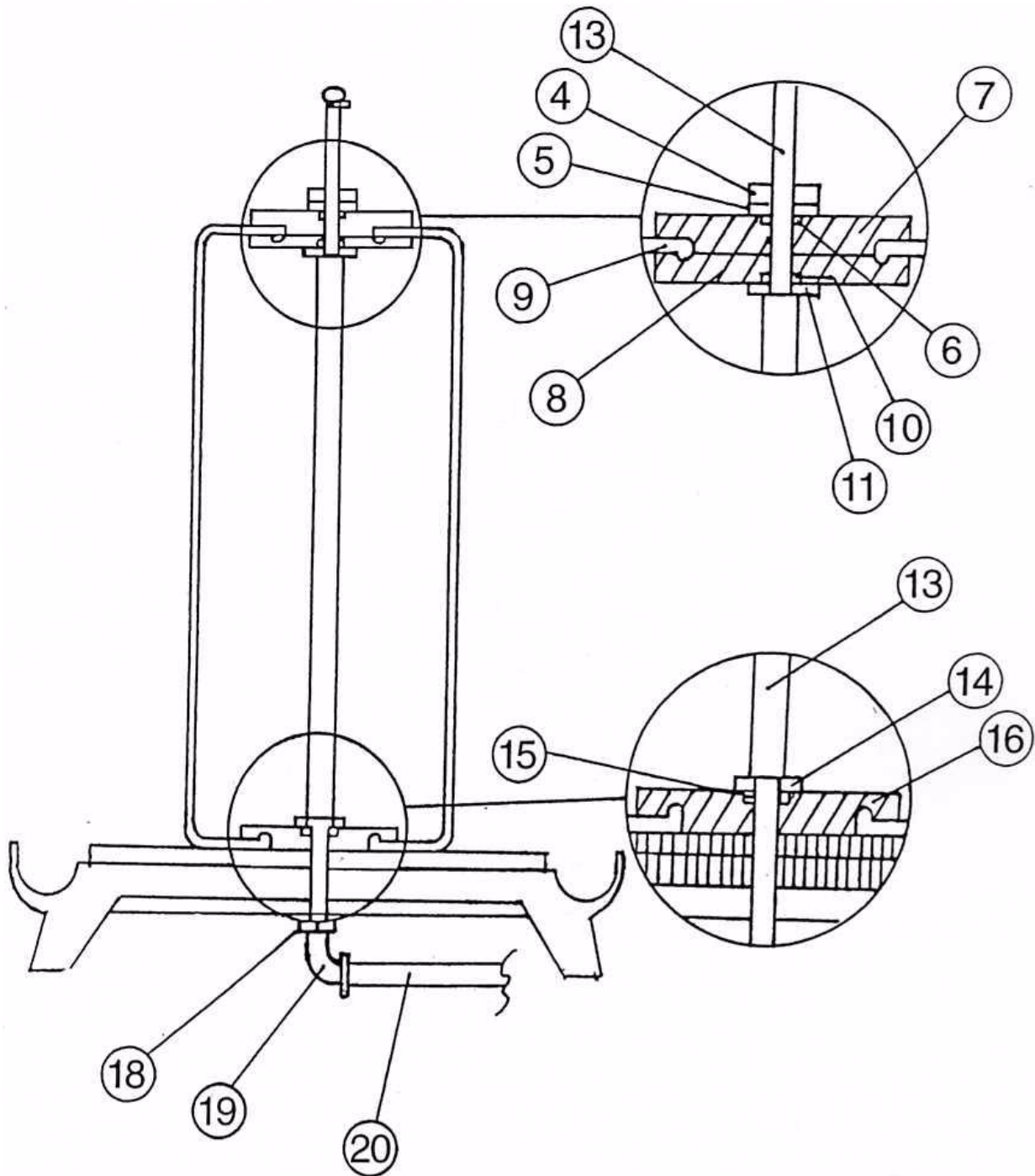

To replace the membrane carefully observe the drawing above and perform the following operations: loosen the lock nut (N°4), remove the washer (N°5), the O-ring (N°6) and the flange (N°7); unscrew the connection pipe (N°20), the bend (N°19) and the lower lock nut (N°18); now remove the shaft (N°13) from the base and replace the membrane.

To reassembly it is advisable to follow the disassembly diagram, making sure that the ribbings of the membrane are in the seat of the flanges (N°8 and N°16). Replace the O-rings (N°6-10-15) if they are worn.

7) GENERAL CONDITIONS OF SALE

- TRANSPORT:** Borne by the purchaser
- CLAIMS:** Claims are only accepted within eight days of receipt of the goods and no returns are accepted unless authorized by us and carriage free.
Goods travel at the risk and peril of the customer.
- IMPORTANT** The manufacturer ZAMBELLI ENOTECH declines all responsibility for failure to comply with our booklet or improper use of the machine.
If you are unsure of how to perform any operation, contact the manufacturer or authorized dealer.
- RESERVATIONS:** We are not responsible for breakages or damages deriving from uses differing from those for which the goods are intended, or for use that does not comply with the capacity and flow rate of the goods.
Flaws and defects caused by wear of parts naturally subject to wear, or returned parts that have been dismantled, tampered with or repaired outside our headquarters are not covered by warranty.
- WARRANTY:** Our products have been carefully tested and inspected and are guaranteed for 2 years from delivery.
Our responsibility is limited to the replacement of any parts found to be defective after careful examination and not caused by improper use by the operator and to be carried out at our headquarters or at the customer's premises charging for transport and labour costs.
- DISPUTES:** The court with jurisdiction is the Court of Vicenza.
- TECHNICAL DATA:** The technical data in this booklet are informative and not binding. The manufacturer reserves the right to make modifications to products without prior notice.

ZAMBELLI ENOTECH SRL
Via dell'Artigianato Z.A.
36043 Camisano Vicentino (VI) Italy
Tel. 0444/719402 Fax 0444/719423
e-mail info@zambellienotech.it www.zambellienotech.it